



Freedom Motors



Freedom Motors

Jurgenstraße 10
D-47574 Goch

Tel. +49 2823 929 96 22
Fax +49 2823 929 96 23
E-Mail: mail@freedommotors.de
www.liftundgo.de

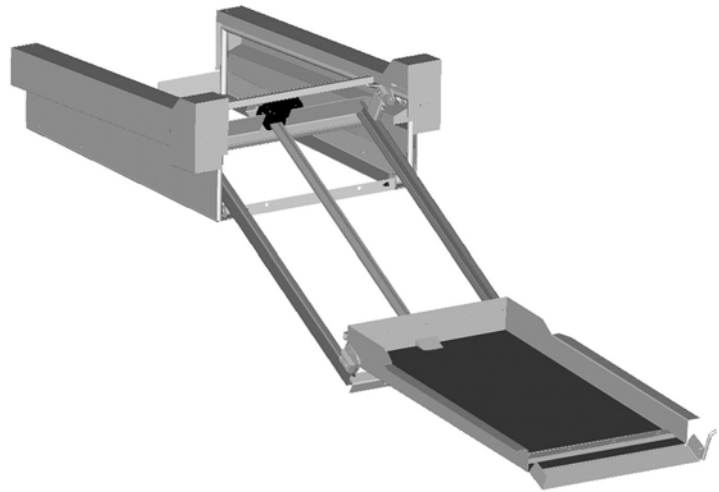

Angaben zur Person:

Name:
Vorname:
Straße, Nr.
PLZ, Ort:
Telefon:
E-Mail:

Angaben zum Elektromobil: *(Sehe Illustrationen auf der nächster Seite)*

Marke:
Typ:
Länge:
Breite:
Höhe:

Angaben zum Fahrzeug:

Marke:
Type:
Baujahr:
Länge Laderaum:
Breite zwischen den Radkästen:
Höhe der hinteren Laderaumöffnung:



Freedom Motors

